

FORD

SERIES 725

LOADER

ASSEMBLY INSTRUCTIONS

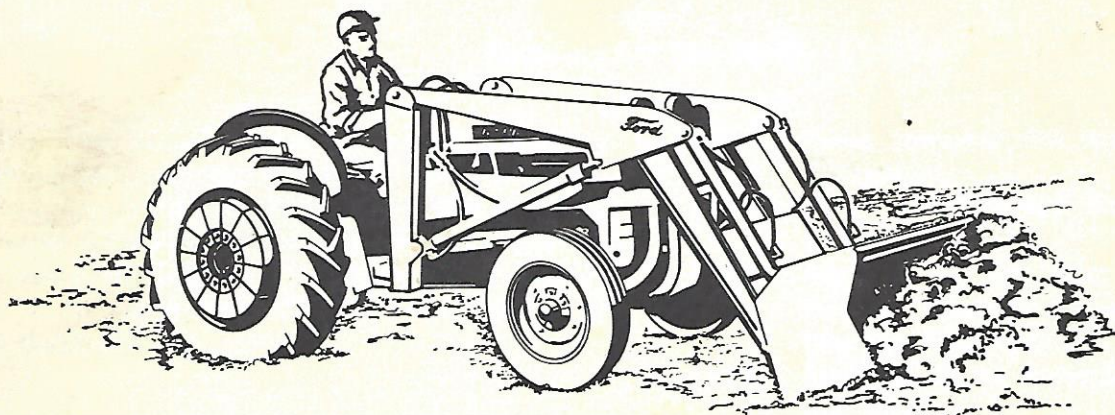

FORD TRACTOR DIVISION
TRACTOR AND IMPLEMENT OPERATIONS (U.S.)
FORD MOTOR COMPANY
BIRMINGHAM, MICHIGAN

CONTENTS

GENERAL INFORMATION	3
SHIPPING INFORMATION	4
ASSEMBLY PROCEDURE	5
Preparing the Tractor	5
19-341 Attaching Kit	6
19-342 Attaching Kit	6
19-338 Hydraulic Kit	6
Installing the Loader	8
Filling the Oil Reservoir	10
Bucket Installation	11
Preparing the Loader for Operation	12
SPECIFICATIONS	13

GENERAL INFORMATION

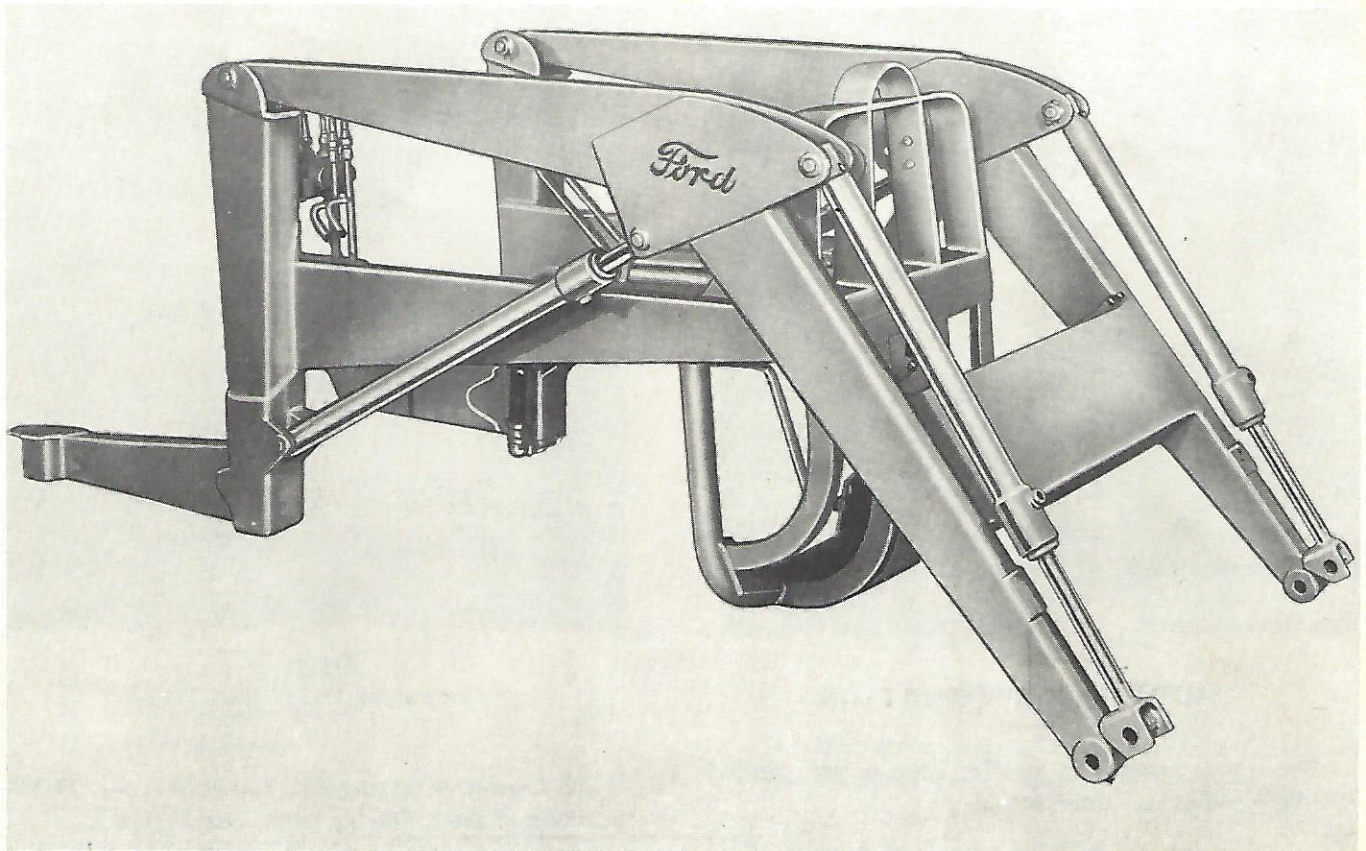

Figure 1
Frame and Lift Arm Bundle

The Series 725 Ford Extra Heavy Duty Loader is a 1600 pound lift capacity loader. The loader is designed for use on Ford Series 2000 and 4000 Industrial Tractors and Ford All-Purpose Tractors equipped with the heavy duty front end. The loader can be mounted on the tractor in conjunction with the Ford 10' or 12' Backhoe.

Before putting the loader in operation, it is necessary to add counterweight to the rear of the tractor. An additional weight of 1600 pounds is necessary for safe operation. Obtain the weight by using rear wheel weights, liquid ballast, or rear attached equipment.

This manual contains shipping information and assembly procedures for the following components of the Series 725 Loader:

- 19-335 Frame Assembly with Double Acting Lift Cylinder
- 19-336 Frame Assembly with Single Acting Lift Cylinder
- 19-341 Attaching Kit for Series 2000-4000 All-Purpose Tractors equipped with Heavy Duty Front End Option.
- 19-342 Attaching Kit for Series 2000-4000 Industrial Tractors.
- 19-338 Hydraulic Attaching Kit.

A backhoe hydraulic kit is available for use in conjunction with the Series 725 Loader. Installation instructions for this kit are furnished with the backhoe.

The Ford Tractor-Equipment Dealer is responsible for the proper assembly and pre-delivery servicing of the loader.

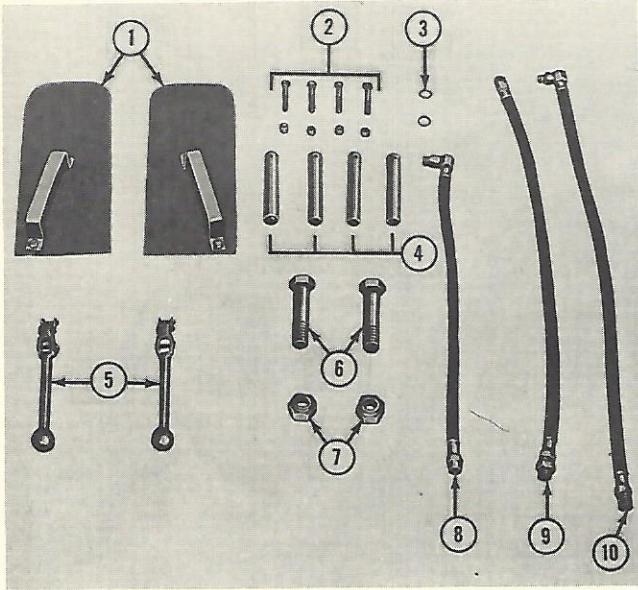

Figure 2

Contents of Parts Bundle

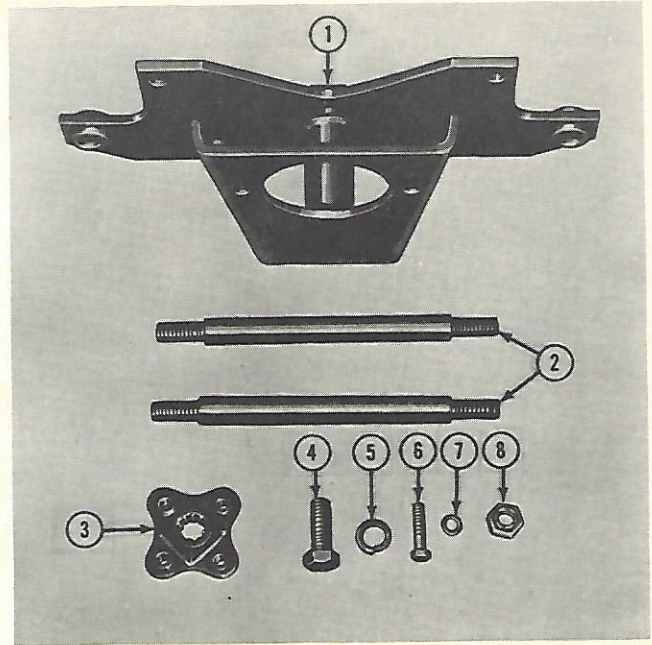

Figure 3

Component 19-341 Attaching Kit

SHIPPING INFORMATION

The Ford Series 725 Loader Frames are shipped in two bundles as listed below:

Component	Bundle No.	Description
19-335	290447	Frame Bundle
	290450	Bag of Parts
19-336	290448	Frame Bundle
	290451	Bag of Parts

The frame bundles consist of the loader frame and lift arms as shown in Figure 1.

The contents of the bag bundles are shown in Figure 2 and listed below.

Reference Figure 2	Description	No. Required	
		B290450	B290451
1	Foot Guard Plates	2	2
2	3/8" x 2-1/2" Hex Bolts and Nuts	4	4
3	"O" Rings	2	2
4	Bucket Attaching Pins	4	4
5	Control Valve Handles	2	2
6	1" x 4-1/2" Hex Head Bolt	2	2
7	1" Hex Lock Nuts	2	2
8	24" Hose	6	4
9	33" Hose	2	2
10	35" Hose	2	2

The Loader Attaching Kit, Component No. 19-341, consists of the following parts. See Figure 3.

Reference Figure 3	Description	Number Required
1	Pump Mounting Plate	1
2	Front Support Rods	2
3	Hub Assembly	1
4	5/8" x 1-1/2" Hex Head Bolts	3
5	5/8" Lock Washers	3
6	7/16" x 1-1/2" Hex Bolts	4
7	7/16" Lock Washers	4
8	3/4" Lock Nuts	4

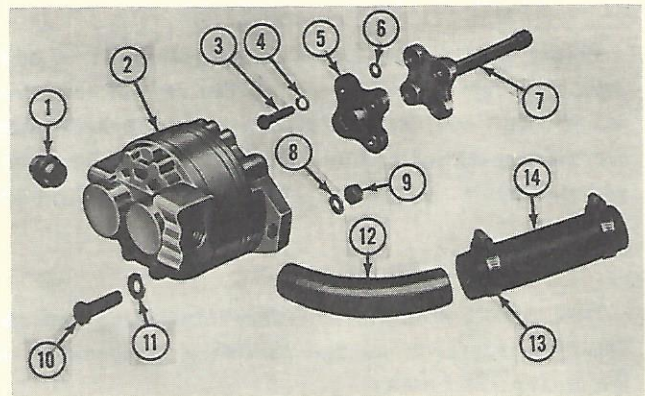

Figure 4

Component 19-338 Hydraulic Kit

ASSEMBLY

The Loader Attaching Kit, Component 19-342, consists of the pump mounting plate and attaching hardware shown in Figure 8.

The Hydraulic Kit, Component 19-338, consists of the following parts. See Figure 4.

Reference Figure 4	Description	Number Required
1	37° Flare Fitting with "O" Ring	1
2	Hydraulic Pump Assembly	1
3	7/16" x 1-3/4" Hex Head Bolt	4
4	7/16" Lock Washer	4
5	Coupling Assembly	1
6	29/64" Diameter Spacer Washer	4
7	Pump Drive Shaft Assembly	1
8	1/2" Lock Washer	2
9	1/2" Hex Nut	2
10	1/2" x 1-3/4" Hex Head Bolt	2
11	1/2" Flat Washer	2
12	Pump Inlet Elbow	1
13	Hose Clamps	2
14	Hose	1

Check the contents of all bundles to make sure all parts are received before starting the assembly.

ASSEMBLY PROCEDURE

The loader can easily be installed on the tractor by using a chain fall or other suitable equipment. The following work must be done on the tractor itself before the loader can be mounted in place.

Preparing the Tractor:

1. Set the tractor rear wheel spacing at a minimum

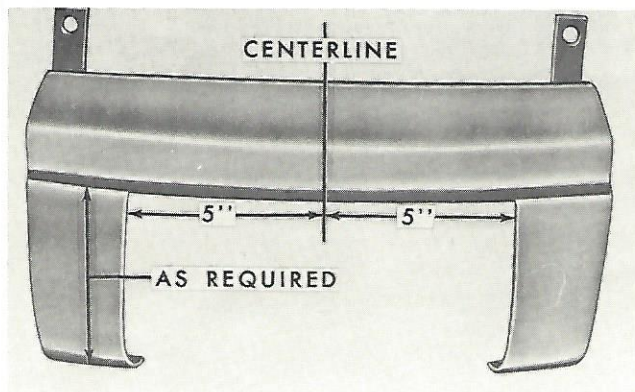

Figure 5
Modifying the Grille

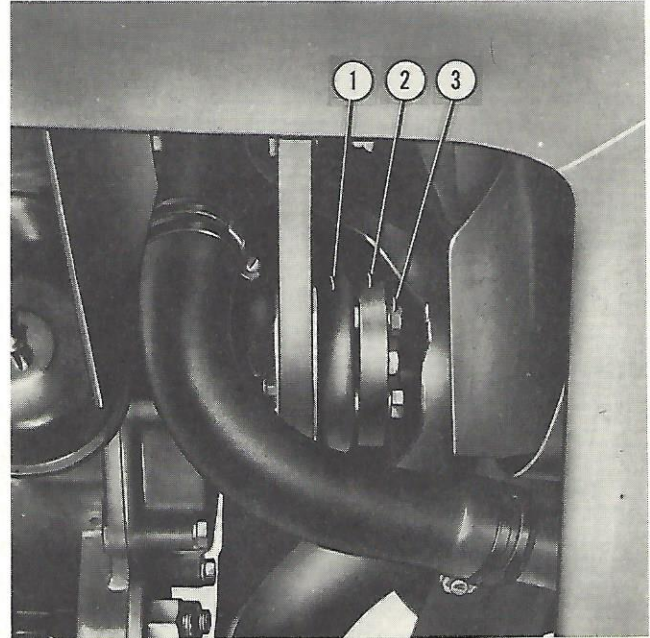

Figure 6
Pump Drive Hub Installed

of 56". Refer to the Tractor Owner's Manual for wheel spacing procedure.

2. Remove the tractor headlights.
3. On Model 2130 and 4130 Diesel Tractors, remove the air cleaner.
4. Modify the radiator grille as follows:
 - a. Remove the grille lower panel from the tractor.

NOTE: On Series 601 Tractors the grille and lower panel are one piece.

 - b. Find the center line of the grille and mark it as shown in Figure 5.
 - c. Cut out the sheet metal to the dimensions shown in Figure 5. Smooth the edges of the sheet metal. The vertical dimension will vary according to the tractor model being used.

NOTE: Reinstall the radiator grille (or lower panel) after the attaching kit and hydraulic kit are installed.
5. Remove and save the nuts and lock washers from the tractor fender bolts.

19-341 Attaching Kit Installation

1. Remove the four bolts from the crankshaft pulley, (1) Figure 6. Be careful not to move the crankshaft pulley after removing the hex head bolts, so as to maintain hole alignment.
2. Position four $7/16'' \times 1-1/2''$ hex head bolts and lock washers in the hub assembly (3), Figure 3. Position the assembly on the front of the crankshaft pulley. Care must be taken to position the hub without dropping the hex head bolts or moving the crankshaft pulley.

IMPORTANT: *If interference is encountered between the hub assembly and the crankshaft bolt, it will be necessary to remove the bolt and install a new thin hex head bolt, Part No. 376540-S8.*

3. Start the four attaching bolts (3), Figure 6, into the crankshaft pulley. After all four bolts are in place, tighten securely.
4. Insert the two $3/4'' \times 12-1/2''$ rods (2), Figure 7, through the holes provided in the engine support and install the $3/4''$ self-locking nuts (1).
5. Position the pump mounting plate assembly (1), Figure 8, over the front of the rods and install

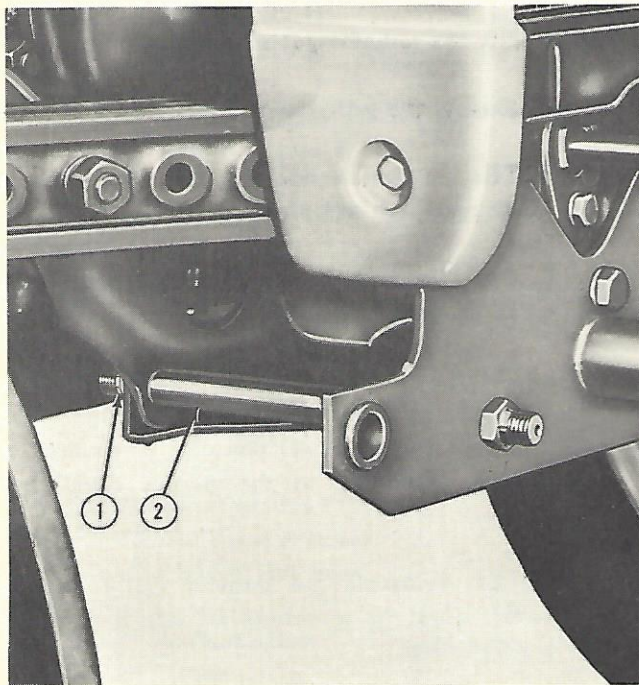

Figure 7
Component 19-341 Support Rods

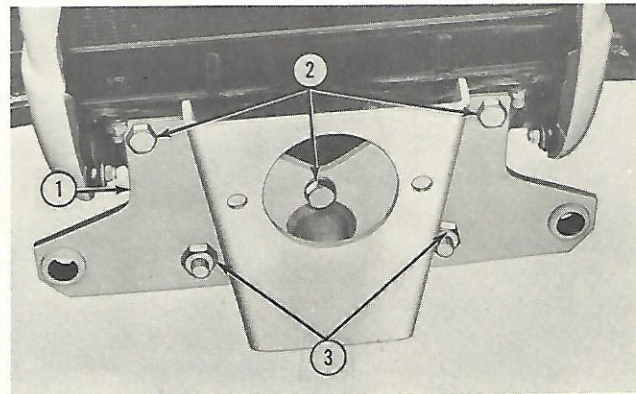

Figure 8
Component 19-341 Pump Mounting Plate

the three $5/8'' \times 1-1/2''$ hex head bolts and lock washer at (2).

6. Install the $3/4''$ self-locking nuts (3), Figure 8, and tighten securely.

19-342 Attaching Kit Installation

Attach the pump mounting plate to the tractor front support with a $5/8'' \times 1-3/4''$ hex head bolt and lock washer at (1), Figure 9. Install two $3/4'' \times 2''$ hex head bolts, lock washers, and nuts at (2).

NOTE: *On tractors after Serial No. 16259, the mounting holes (2) are threaded. On these tractors, discard the $3/4''$ nuts and install the lock washers under the bolt head.*

19-338 Hydraulic Kit Installation

1. Attach the coupling assembly (5), Figure 4, to the pump drive shaft (7) with the four $7/16'' \times$

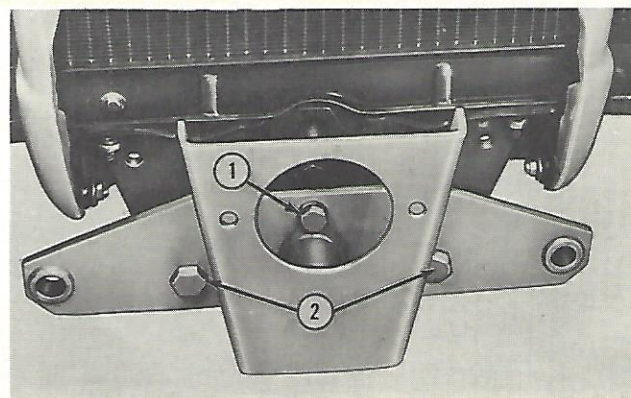

Figure 9
Component 19-342 Pump Mounting Plate

ASSEMBLY

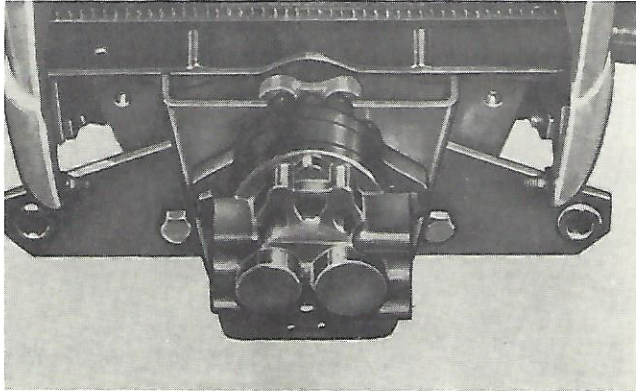

Figure 10
Pump Installed

1-3/4" hex head bolts and lock washers. Do not install the spacer washers at this time.

2. Install the pump drive shaft assembly into the engine drive hub.
3. Slide the pump shaft into the drive coupling and secure the pump to the mounting plate with the

two 1/2" x 1-3/4" hex head bolts, lock washers, and nuts as shown in Figure 10.

IMPORTANT: Do not start the tractor engine with the pump installed until after the loader is on and the hydraulic system is filled with oil.

4. Check the pump drive shaft end clearance as follows:
 - a. Slide the drive shaft forward (toward the pump) until the coupling bottoms on the pump shaft spline.
 - b. Slide the drive shaft back (into the engine drive hub) and note the distance the shaft slides. The shaft end clearance should be maintained between 1/8" and 1/4".
 - c. If the pump drive shaft slides more than 1/4", it will be necessary to install the four 29/64" diameter spacer washers (6), Figure 4, between the coupling assembly and the pump drive shaft assembly.

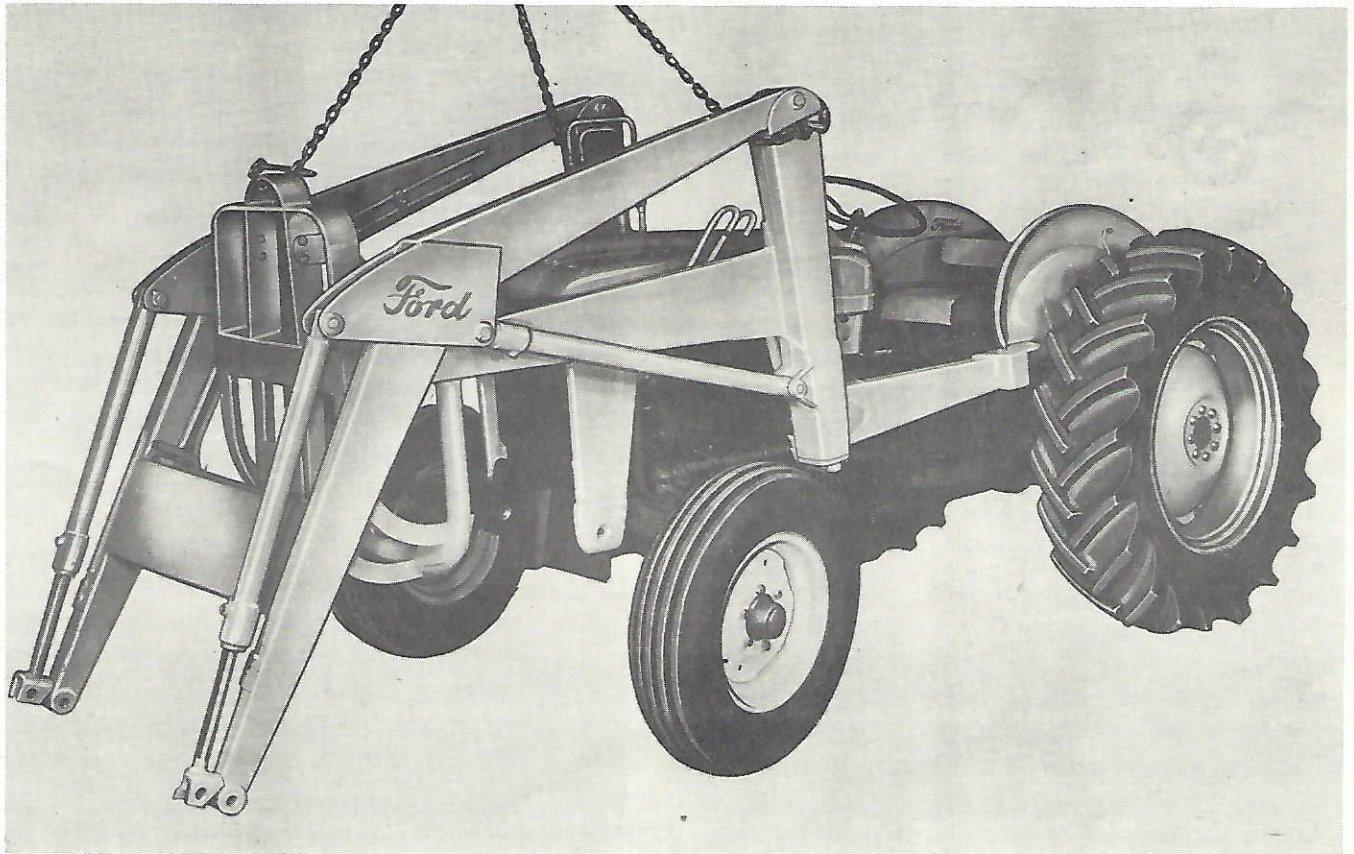

Figure 11
Installing the Loader

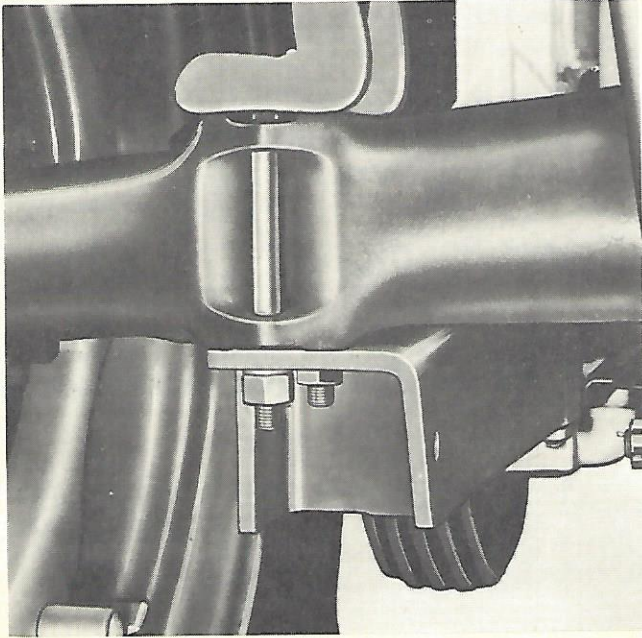

Figure 12
Attaching Loader Frame to Rear Axle

Installing the Loader

1. Install lift chains on the loader as shown in Figure 11.



CAUTION: Make sure the lift chains are not defective and take time to make a secure hook-up.

2. Raise the loader frame high enough for the lift posts to clear the tractor front axle. Roll the tractor forward and lower the loader frame into position.
3. Secure the rear arms to the tractor fender bolts with the lock washers and nuts previously re-

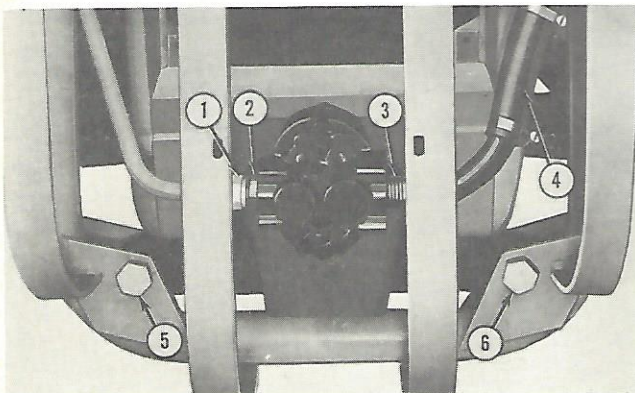

Figure 13
Hydraulic Pump Connection

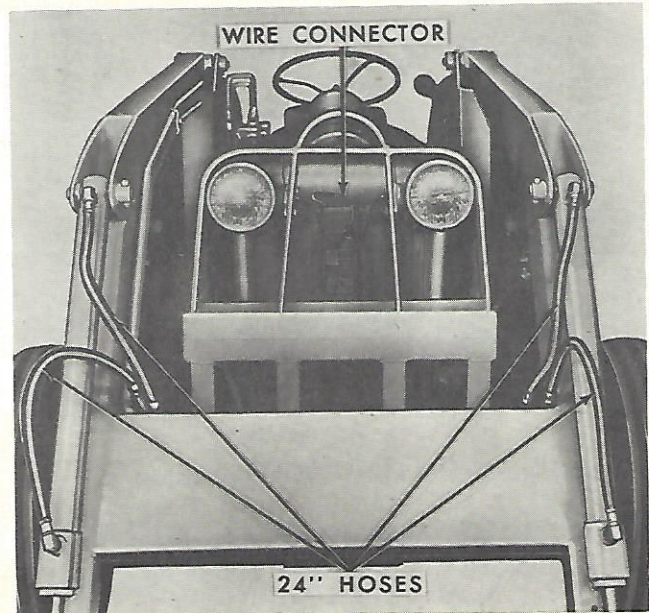

Figure 14
Bucket Cylinder Hoses

moved. See Figure 12.

4. Attach the front of the loader frame to each side of the pump mounting plate as shown at (5) and (6), Figure 13, with the two 1" x 4-1/2" hex head bolts and lock nuts.

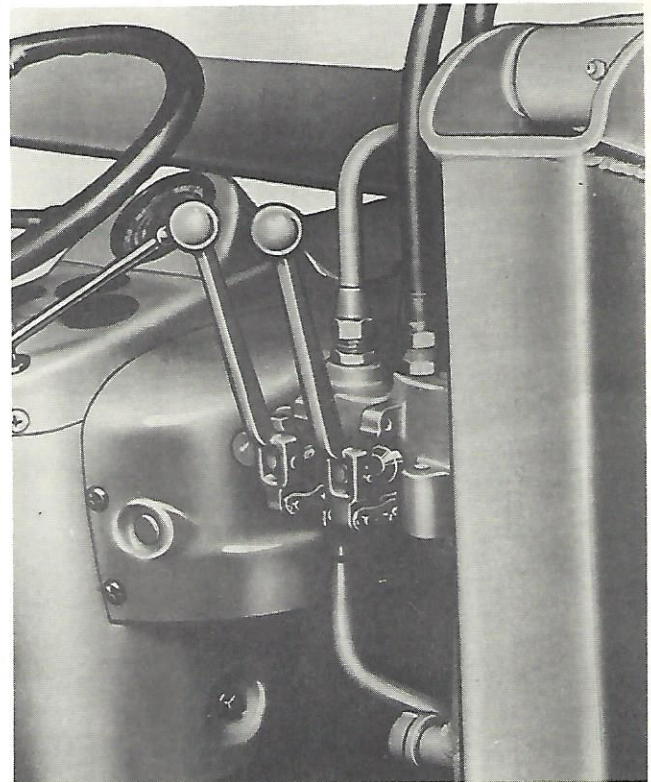

Figure 15
Control Valve Handles Installed

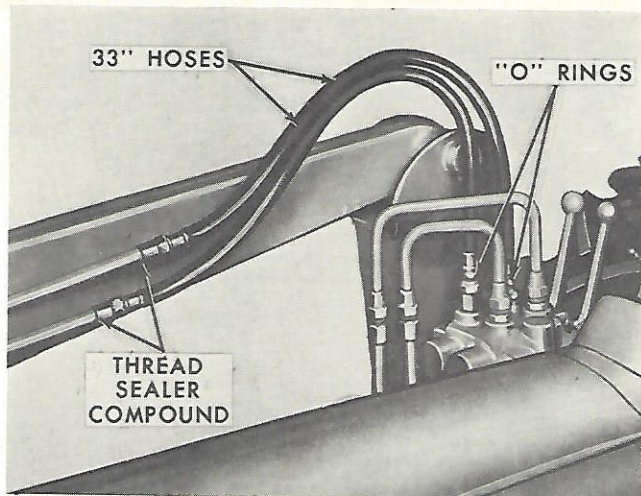

Figure 16

Component 19-335 Control Valve Hoses

5. Install the 37° flare fitting and "O" ring in the pump at (2), Figure 13. Connect the pump pressure tube (1) to the flare fitting.
6. Apply M-5837-B Thread Sealer Compound on the threader of the inlet elbow and install the elbow in the pump as shown at (3), Figure 13.
7. Install the hose (4) and the hose clamps on the pump inlet elbow and return tube as shown. Slide the filter to pump tube forward as required to obtain hose clearance at the step plate. Rotate the elbows to provide proper hose alignment.
8. Apply thread sealer compound on the threads of the bucket cylinder hoses and install the hoses as shown in Figure 14.

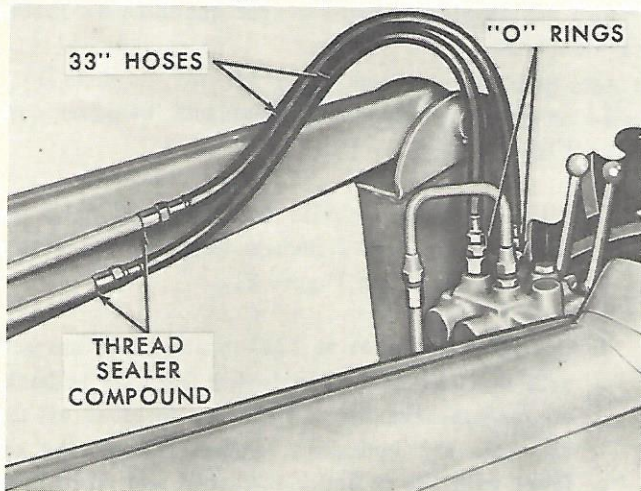

Figure 17

Component 19-336 Control Valve Hoses

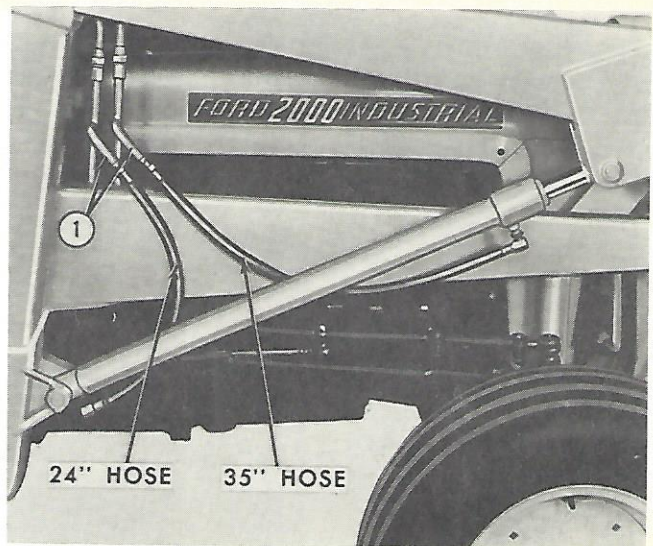

Figure 18

Component 19-335 Lift Cylinder Hoses

9. Attach the control valve handles in the position shown in Figure 15 with the clevis pins and cotter pins provided.
 10. Install the control valve hoses and "O" rings as shown in Figure 16 for Model 19-335, or Figure 17 for Model 19-336.
- NOTE:** Coat the "O" rings with oil before installation.
11. Apply thread sealing compound to the threads of the lift cylinder hoses. Install the lift cylinder hoses as shown in Figure 18 for Model 19-335, or Figure 19 for Model 19-336.

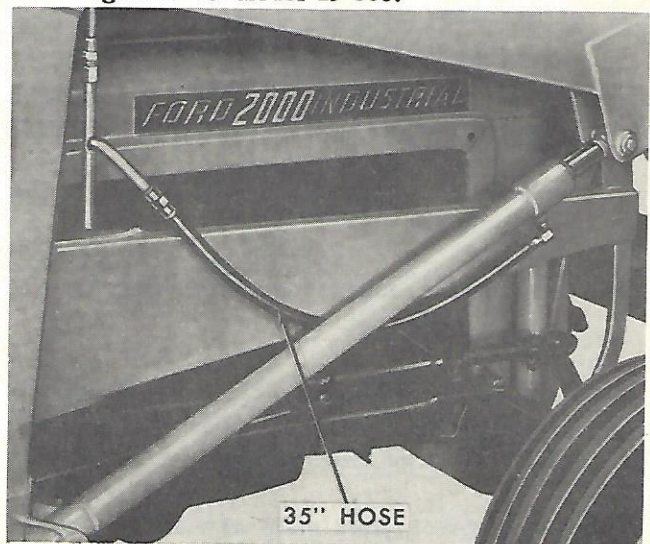

Figure 19

Component 19-336 Lift Cylinder Hoses

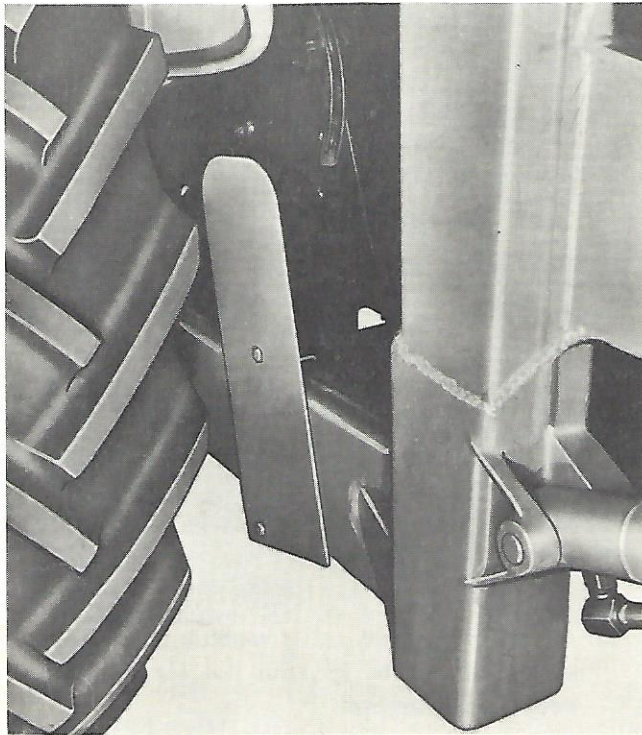

Figure 20
Foot Guard Plate

IMPORTANT: When installing the lift cylinder hoses, be sure the tubes (1), Figure 18, are positioned to allow the hoses to come straight down along side of the loader frame.

12. Adjust the right brake pedal inward, as required, so the pedal does not contact the loader frame when depressed. When properly adjusted, it may be necessary to cut off the end of the right pedal to prevent contact with the left pedal
13. On Model 2130 and 4130 Diesel Tractors install the air cleaner.
14. Install the headlights on the loader frame as shown in Figure 14.
15. Re-route the original headlight wire through the tractor grille. Connect the headlight wires with the connector provided as shown in Figure 14.
16. Install a foot guard plate on each side of the loader frame as shown in Figure 20.

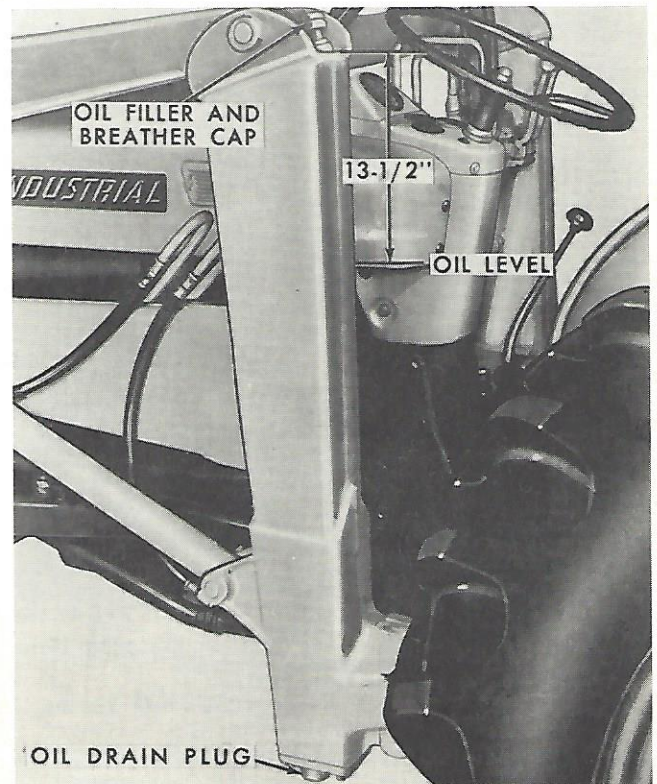

Figure 21
Oil Filler and Breather Cap



CAUTION: Clamp the plates in a position that will protect the operator's feet from accidentally contacting the tractor tires.

Filling The Oil Reservoir

The loader hydraulic system oil capacity is 9 gallons. Ford Specification M-2C-41 hydraulic oil (sold separately) is recommended for the best loader performance.

1. Remove the reservoir filler and breather cap, Figure 21.
2. Fill the reservoir with hydraulic oil until the oil level is 13-1/2 inches from the top of the filler opening. See Figure 21.
3. Operate the tractor at 1200 to 1500 rpm and actuate the lift and bucket levers (no load in bucket) for approximately 15 minutes to bleed all the air from the hydraulic system. Check the oil level with the cylinder retracted and add oil as required.

ASSEMBLY

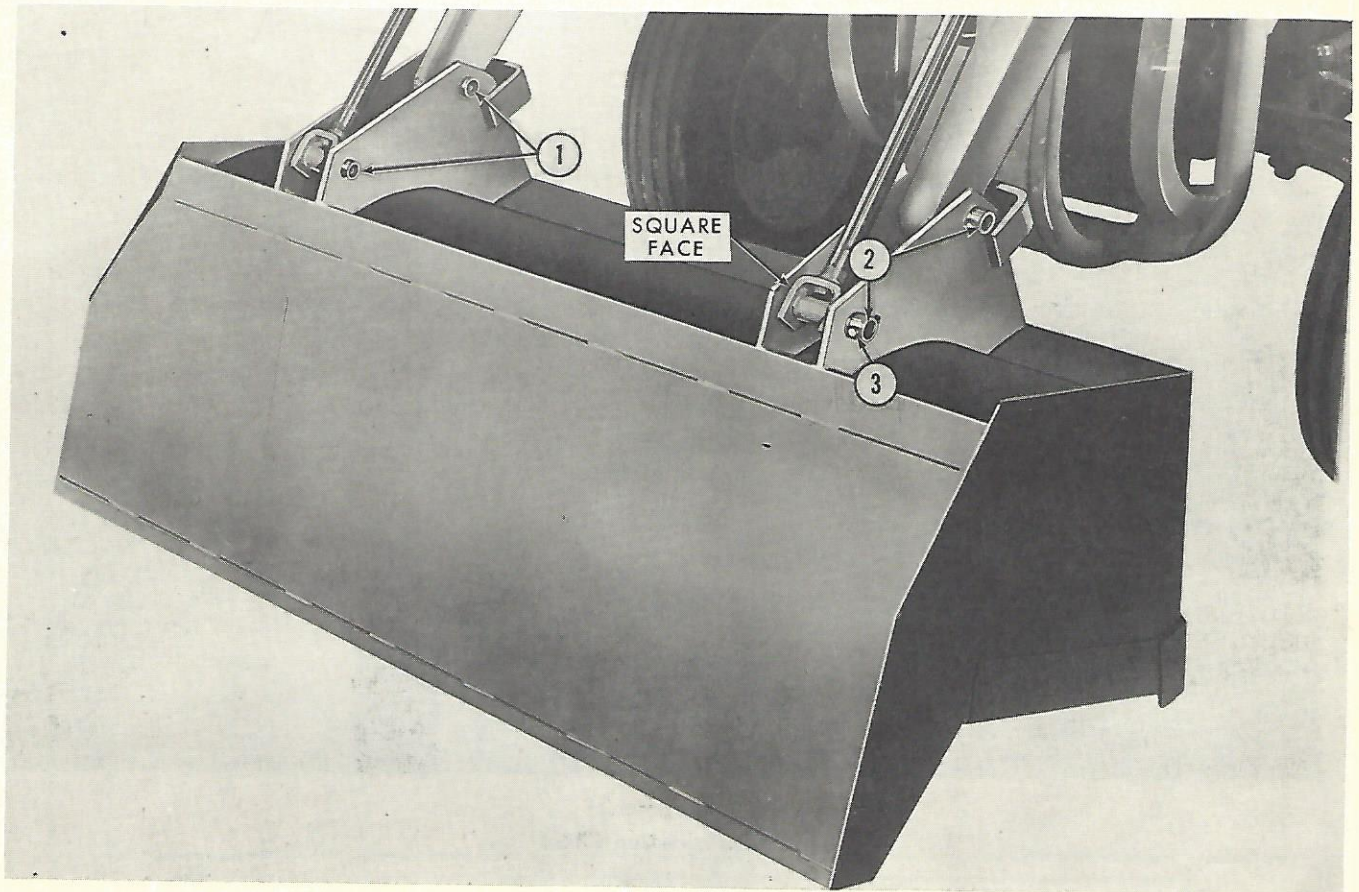

Figure 22
Attaching Bucket

Bucket Installation

1. Position the bucket, lift arms, and cylinder rods as shown in Figure 22.
2. Install the 1" x 6" bucket attaching pins as shown at (2) and (3). Secure each pin with a

3/8" x 2-1/2" grade 5 hex head bolt and self-locking nut (1).

NOTE: The square face of the cylinder rod must be forward as shown. The longer portion extends toward the lift arm and provides a bucket stop when the bucket cylinder is retracted.

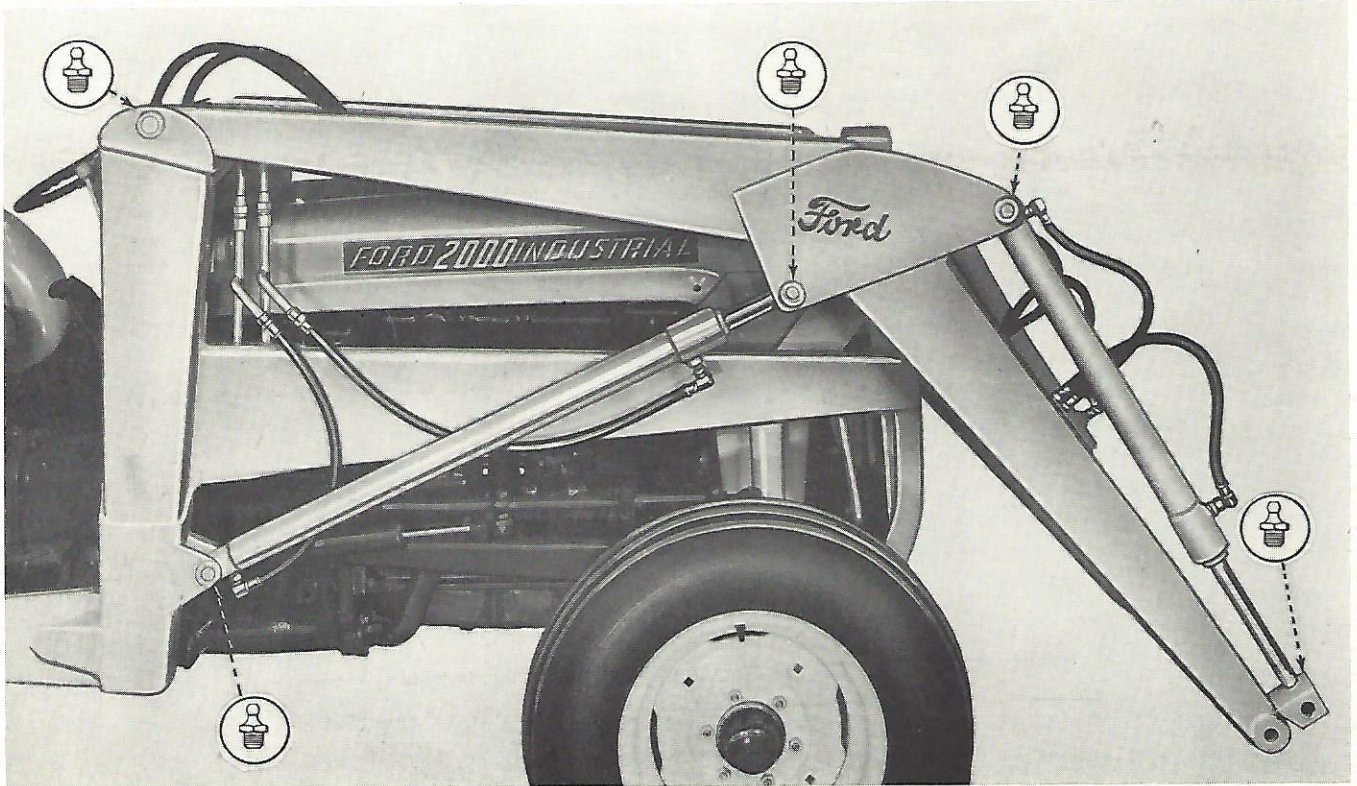

*Figure 23
Lubrication Chart*

Preparing The Loader For Operation

1. Grease the loader through the ten lubrication fittings. Figure 23 shows the five fittings on the right side of the loader. The other five are on the left side in the same location.
2. Add the required counterbalance weight to the rear of the tractor.
3. Check the operation of the loader and observe the hydraulic connections for signs of leakage.
4. Check the relief valve pressure as follows:
 - a. Shut off the tractor engine.
 - b. Relieve the pressure by actuating the valve handles.
 - c. Remove the rear bucket cylinder hose and insert a pressure gauge in the port opening.
 - d. Start the tractor engine, actuate the right control valve handle and observe the pressure reading on the gauge.

The correct relief valve pressure is 1600 psi \pm 50 psi, with pump flow at 1500 engine rpm. If the relief valve pressure is not within these limits adjust as follows:

- a. Remove the relief valve cap.
- b. Add or remove shims (.010 thick) as required to obtain the correct pressure. Each shim changes the pressure approximately 100 psi.

SPECIFICATIONS

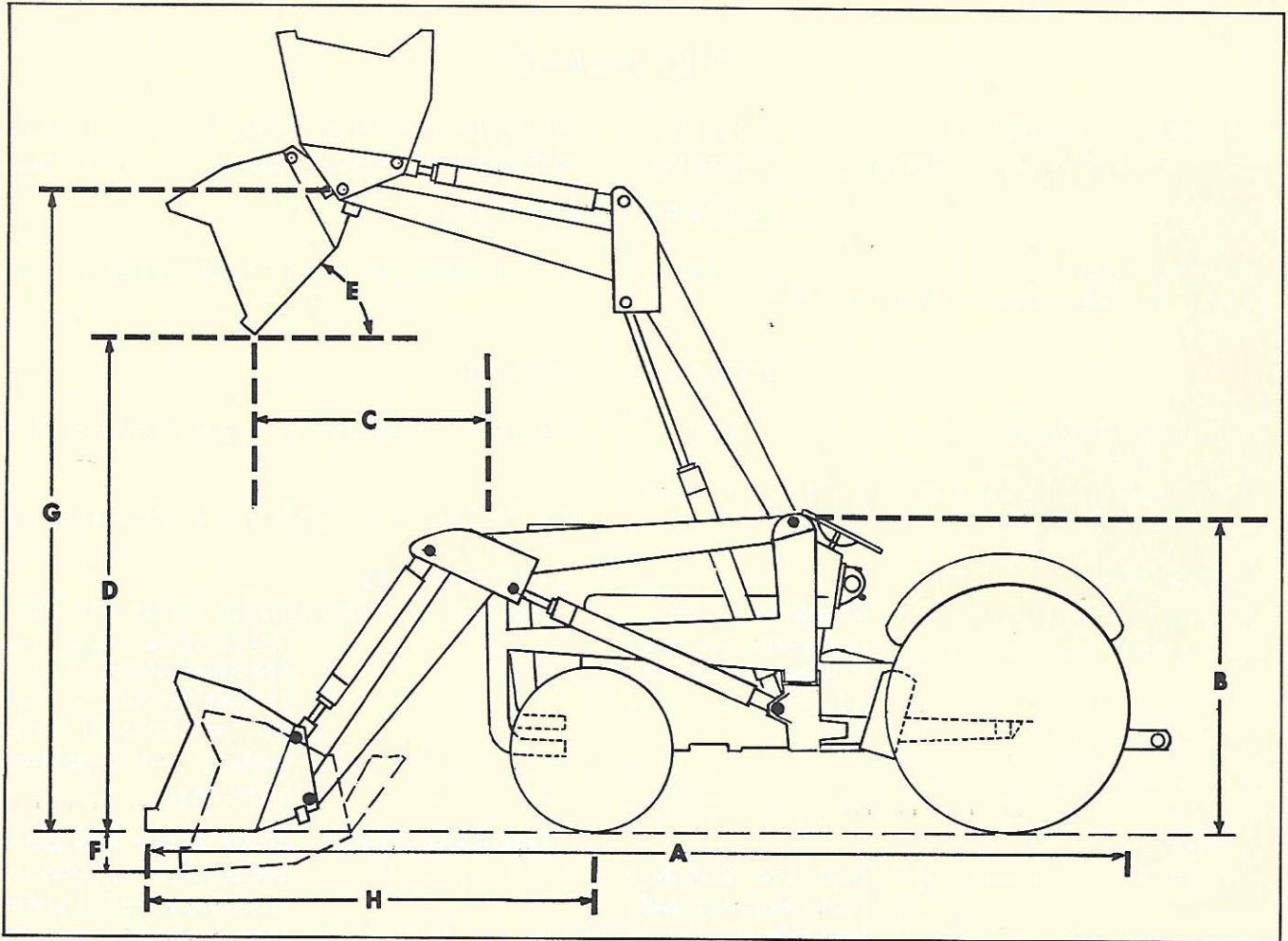

A	13'10-1/2"
B	4'9"
C	19-1/2" at 43°
D	8'6" at 43°
E	43°
F	4"
G	10'4-3/8"
H	66-1/2"
Approx. Shipping Weight	1000 lbs.

The above dimensions are based on a Ford Series 4000 All-Purpose Tractor equipped with 13.6-28 rear tires, 6:50-16 front tires, and a 19-333 material bucket.

SPECIFICATIONS

PERFORMANCE

BREAKAWAY CAPACITY.....	2590 lbs.	SPEED OF LIFT (Full Load).....	4.5 Secs.
LIFT CAPACITY-FULL HEIGHT.....	1600 lbs.	SPEED OF DROP (No Load)	2.2 Secs.

BUCKET OPERATION

BUCKET DUMP.....	2 Secs.	BUCKET ROLL BACK AT GROUND LEVEL....	23°
BUCKET DUMP ANGLE AT FULL LIFT.....	43°		

HYDRAULIC SYSTEM

RELIEF PRESSURE.....	1600 psi
OIL CAPACITY.....	9 gals.

Main frame is reservoir with filler boss and breather on top of left lift post.

RESERVOIR:

Type.....	Main frame structure
Location.....	Horizontal members of front of frame and L.H. lift post.

PUMP

Type.....	Gear type with instant response and high volume.
Capacity At 2200 rpm.....	15.5 at 1600 psi
Mounting.....	Direct to front mounting bracket; not on loader frame.

Drive.....	Splined drive shaft with flexible coupling to protect the pump from shock loads.
------------	--

CONTROL VALVE (Component 19-335):

Type . Double spool, open center, with 3 position spools to control lift cylinders and 3 position spools to control tilt cylinders. Spring-loaded spools for self-centering in neutral position. Anti-cavitation check for tilt cylinders.

Flow Capacity..... 20 gpm

CONTROL VALVE (Component 19-336):

Type..... Same as component 19-335 except with 2 positions to control single acting lift cylinders.

OIL SPECIFICATION... Ford Specification M-2C-41

OIL FILTER..... Full flow - Throw-away type

LIFT CYLINDERS:

Type (Comp. 19-335)... Double Acting with ground and polished cylinder rod, chromium plated. Cylinder of seamless tubing. Cylinder has fabricated V-ring packing and a neoprene wiper ring.

Type (Comp. 19-336)... Single Acting with ground and polished cylinder rod, chromium plated. Cylinder tube is standard seamless pipe. Cylinder head has fabricated V-ring packing and a neoprene wiper ring.

Number (Comp. 19-335).....	2 Double Acting
Number (Comp. 19-336).....	2 Single Acting
Extended Length.....	76"
Retracted Length.....	42-11/16"
Stroke.....	33-21/64"
Piston Diameter.....	2"
Rod Diameter (Comp. 19-335).....	1-1/2"
Rod Diameter (Comp. 19-336).....	2"

BUCKET CYLINDERS:

Type..... Double acting with chromium plated cylinder rods, turned, ground and polished. V-ring packings and a neoprene wiper ring.

Extended Length.....	51-3/8"
Retracted Length.....	31-5/16"
Stroke.....	20"
Piston Diameter.....	2"
Rod Diameter.....	1-1/4"

SPECIFICATIONS

PERFORMANCE

REAR HUB CAPACITY 17,000 LBS. (7,700 kg.) FRONT HUB CAPACITY 10,000 LBS. (4,500 kg.)

EXACT SPECIFICATIONS

WEIGHT 11,000 LBS. (5,000 kg.) WITH FRONT END WEIGHT 14,000 LBS. (6,300 kg.)

OPERATIONAL DATA

MAXIMUM GRADEABILITY 25% MAXIMUM SPEED 20 MPH (32 km/h)

MAXIMUM FUEL CAPACITY 40 GALLONS (151.4 L) MAXIMUM FUEL CONSUMPTION 1.5 GPM (56.8 L/h)

A PRODUCT OF



MOTOR COMPANY

Ford Motor Co., Inc.

Prepared by

TRACTOR AND IMPLEMENT OPERATIONS (U.S.)

FORD TRACTOR DIVISION FORD MOTOR COMPANY

BIRMINGHAM, MICHIGAN

"Ford Motor Company, whose policy is one of continuous improvement, reserves the right to make changes in design and specifications at any time without notice and without obligation to modify units previously built."